

YUEQING HONGYI ELECTRONICS CO., LTD  
乐清市宏一电子有限公司

SPECIFICATION FOR APPROVAL

承认书

CUSTOMER 客户名称	
DESCRIPRION 产品名称	XH 板对板系列连接器
ITEM NO 编 号	HY-A25010 (A78)
DATE 日 期	2022-9-16

CUSTOMER ACKNOWLEDGEMENT SEAL

客户承认印签

(APPROVAL) 核准	(ENGINEERING) 工程	(PURCHASE) 采购	(QUALITY) 品质
承认结果: <input type="checkbox"/> 通过 <input type="checkbox"/> 不通过 <input type="checkbox"/> 重新送样			

IS09001

IS014001

IS045001

IATF16949 体系认证

ADD: No. 30, Wenjing Road, Houyu village, Shifan street, Yueqing City, Zhejiang Province

地址: 浙江省乐清市石帆街道后屿文景路 30 号

TEL:0577-62380521

FAX: 0577-62381979 P.C:325608

http: //www.zhehongyi.com

E-MAIL:yaohongxiao88@126.com



# 产 品 承 认 书 目 录

1、封面	1-1
2、修订履历	2-2
2、目录	3-3
3、技术规范	4-10
4、产品图纸	11-12

# PRODUCT SPECIFICATION

## 产品规范

### 1、Scope

#### 适用范围

This specification includes the following specifications, including the specification of 2.50mm pitch XH Board to board series connector

本规范包括下列此种规格包括 2.50mm Pitch XH 板对板系列连接器规格说明

### 2、Appearance and Dimension

#### 外观及尺寸

2.1 Appearance: Product surface without defect, dirt, crack, and mechanical damage, Contact without rust, plating not oxidized and not peeled.

产品表面不应有对制品有害的缺陷、污垢、裂痕及机械损伤；接触件无锈蚀、镀层氧化脱落等现象

2.2 Dimension: According to drawings

外形尺寸：依照附图

### 3、Disposal of Material and surface

#### 材料与表面处理

Specification 规格内容	Material 材质	Finish 表面处理	Environmental protection grade 环保等级
Wafer 直针座	Plastic 塑壳 PA66 UL94V-0	Color: White 颜色：白色	RoHS2.0
	Contact 插针 Phosphor bronze 磷铜 厚 0.30mm	Tin Plating: 2.5~5 μm 镀锡：2.5~5 μm	
Wafer 直针座	Plastic 塑壳 PA66 UL94V-0	Color: White 颜色：白色	
	Contact 插针 Phosphor bronze 磷铜 厚 0.30mm	Tin Plating: 2.5~5 μm 镀锡：2.5~5 μm	

#### 4、Ratings and applicable wires

##### 额定等级

Item 项目	Standard 规格
Rated Voltage 额定电压	250V AC/DC
Rated Current 额定电流	3A AC/DC
Ambient temperature Range 使用温度范围	-25°C - +85°C

#### 5、Electrical Performance

##### 电气性能

N0. 序号	Ltem 项目	Test mode 试验方法	Requirement 技术要求
5.1	ContactResistance 接触电阻	Male female cooperation, open voltage less than 20mV, current 100mA detection connector at both ends  公母配合, 开放电压20mV 以下, 电流100mA 检测连接器连接器两端	Initial:20mΩ Max 初始: 20mΩ Max  After Test: 30mΩ Max 试验后: 30mΩ Max
5.2	withstandvoltage 耐电压	Mate connectors, apply 1000V AC for 1 minute between adjacent terminal or ground  公母配合, 在相邻端子, 端子与地片之间, 使用1000V 的交流电1 分钟, 检测连接器	No Breakdown and Flashover  外观无损伤, 无打火花
5.3	InsulationResistance 绝缘电阻	Mate connectors, apply 500V DC between adjacent terminal or ground  公母配合, 在相邻端子, 端子与地片之间, 使用500V 的直流电, 检测连接器	1000MΩ Min

## 6、机械性能

### Mechanical Performance

N0. 序号	Ltem 项目	Test mode 试验方法	Requirement 技术要求
6.1	Terminal/ Housing Retention Force 端子保持力	Apply axial pull out force at the speed rate of $25.4 \pm 3\text{mm}/\text{minute}$ on the terminal assembled in the Housing  以每分 $25.4 \pm 3\text{mm}$ 的速率, 将端子从 Housing 内轴向拔出力	Per contact: 15N Min 单一接触点: 15N Min
6.2	Insertion & withdraw Force 插拔力	Insert and withdraw Connectors at the speed rate of $25.4 \pm 3\text{mm}/\text{minute}$  以每分 钟 $25.4 \pm 3\text{mm}$ 的速率插入和拔出	Refer to paragraph 8 参照第 8 项

## 7、Endurance Characteristics:

### 环境性能

N0. 序号	Ltem 项目	Test mode 试验方法	Requirement 技术要求	
7.1	Repeated Insertion/ Withdrawal 重复插拔	When mated up to 30 cycles repeatedly by the rate of 10 cycles per minute  以每分 钟不超过 10 次的速率, 将公母插拔 30 次	Contact Resistance 接触电阻	30 m $\Omega$ Max
7.2	Temperature Rise 温升测试	Mating connectors shall be energized at rating current until thermal stability is achieved, and then measured the temperature rise  公母连接器配合后, 加载额定电流直到温度上升到稳定 状态, 然后再测量温升	Temperature Rise 温升测试	30 $^{\circ}\text{C}$ Max
7.3	Vibration test 振动测试	Amplitude: 1.5mm P-P Sweep time: $10 \sim 55 \sim 10$ HZ in 1 minute Duration: 2 hours in each X.Y.Z axials  振幅: 1.5mm P-P 时间: $10 \sim 55 \sim 10$ HZ in 1 minute 持续时间: 每轴向 2 小时	Appearance 外观	No damage 无异常
			Contact Resistance 接触电阻	30 m $\Omega$ Max
			Discontinuity 瞬断	1 micro-second Max.

NO. 序号	Item 项目	Test mode 试验方法	Requirement 技术要求	
7.4	Heat Resistance 耐热性	85±2°C,96 hours	Appearance 外观	No damage 无异常
			Contact Resistance 接触电阻	30 mΩ Max
7.5	Cold Resistance 耐寒性	-25±3°C,96 hours	Appearance 外观	No damage 无异常
			Contact Resistance 接触电阻	30 mΩ Max
7.6	Humidity 耐湿性	Temperature: 60±2°C Relative Humidity: 90~95% Duration: 96 hours  温度: 60±2°C 湿度: 90~95%(RH) 持续时间: 96 hours	Appearance 外观	No damage 无异常
			Contact Resistance 接触电阻	30 mΩ Max
			Withstand Voltage 耐电压	No Breakdown and Flashover 外观无损伤, 无打火花
			Insulation Resistance 绝缘电阻	1000MΩ Min
7.7	温度变化 Temperature Cycling	5 cycles of: a) -25°C 30 minutes b) +85°C 30 minutes  从-25°C持续30 分钟升至+85°C持续30 分钟,循环5 次	Appearance 外观	No damage 无异常
			Contact Resistance 接触电阻	30 mΩ Max
7.8	Salt spray 盐雾	24±1 hours exposure to a salt spray from the 5±1% solution at 35±2°C  在温度35±2°C, 盐水浓度5±1%下, 盐水喷 雾24±1 小时	Appearance 外观	No damage 无异常
			Contact Resistance 接触电阻	30 mΩ Max
7.9	Solderability 焊锡附着性	Soldering Time: 3-5sec solder Temperature: 245±5°C  焊接时间: 3-5 秒 焊接温度: 245±5°C	Solder Wetting 焊料润湿	Immersion area above 95%  浸渍面积 95% 以上

NO. 序号	Ltem 项 目	Test mode 试验方法	Requirement 技术要求	
7.10	Solder- Resistance 焊锡耐热性	<p>DIP type PA66 material welding heat resistance range: Soldering time:3~5sec solder. Temperature:230±5℃ DIP 型 PA66 材质焊接耐热范围: 焊接时间: 3~5 秒. 焊接温度: 230±5℃</p> <p>DIP type PA46 material welding heat resistance range: Soldering time:3~5sec solder. Temperature:245±5℃ DIP 型 PA46 材质焊接耐热范围: 焊接时间: 3~5 秒. 焊接温度: 245±5℃</p>	Appearance 外观	No damage 无异常



## 8、INSERTION/WITHDRAWAL FORCE

## 综合插入力及拔出力

No. of CTK PIN 数	At Initial 初始值		At 30th 插拔 30 次	No. of CTK PIN 数	At Initial 初始值		At 30th 插拔 30 次
	I. F (N Max) 插入力	W. F (N Min) 拔出力	W. F (N Min) 拔出力		I. F (N Max) 插入力	W. F (N Min) 拔出力	W. F (N Min) 拔出力
2	30	7	6	12	80	23	20
3	35	7	6	13	85	27	23
4	40	11	10	14	90	27	23
5	45	11	10	15	95	30	26
6	50	15	14	2*4A	55	14	12
7	55	17	16				
8	60	17	16				
9	65	20	18				
10	70	20	18				
11	75	23	20				

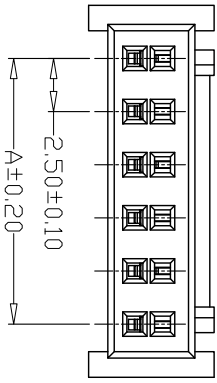

- SPECIFICATIONS
- 1、Current Rating: 3A AC, DC
  - 2、Voltage Rating: 250V AC, DC
  - 3、Temperature Range: -25°C~+85°C
  - 4、Contact Resistance: 20mΩ Max
  - 5、Insulation Resistance: 1000MΩ Min
  - 6、Withstanding Voltage: 1000V AC/minute
  - 7、Material: Wafer PA66, UL94V-0  
PIN Phosphor bronze Tin-plated

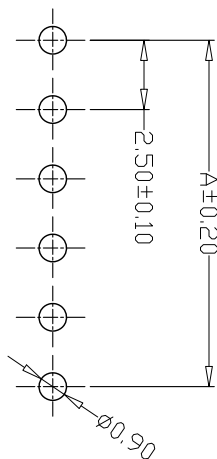
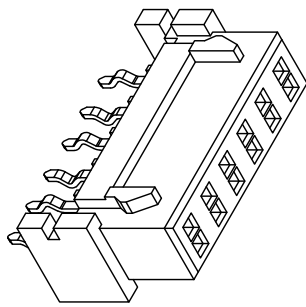

PCB LAYOUT

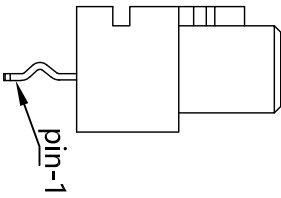
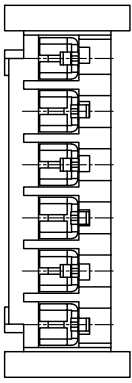
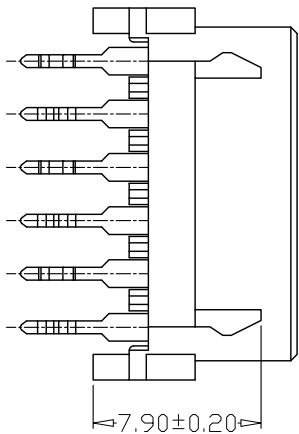
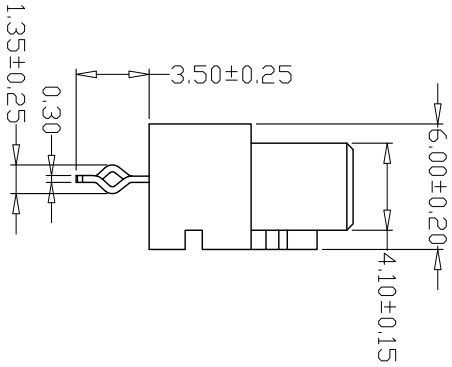
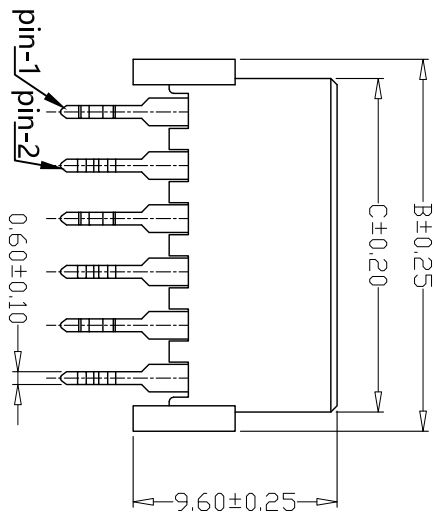

任何孔位第1针打方向

版本 REV.	日期 DATE	ECN NO.	变更内容 DESCRIPTION	制图 DRAWN

PIN	尺寸 (mm)		
	A	B	C
-02P	2.50	7.50	5.70
-03P	5.00	10.00	8.20
-04P	7.50	12.50	10.70
-05P	10.00	15.00	13.20
-06P	12.50	17.50	15.70
-07P	15.00	20.00	18.20
-08P	17.50	22.50	20.70
-09P	20.00	25.00	23.20
-10P	22.50	27.50	25.70
-11P	25.00	30.00	28.20
-12P	27.50	32.50	30.70
-13P	30.00	35.00	33.20
-14P	32.50	37.50	35.70
-15P	35.00	40.00	38.20

GENERAL TOLERANCE		制图 Mapping		料号	
X±0.25	X°±2°	2022、09、15	张迎春	PART NO.	A25010-nP
.X±0.25	.X°±1°	审核 Audit	钱岳生	品名 TITLE	XH板对板直针
.XX±0.15	.XX°±0.5°	批准 Approved	张名	客户料号 CUTM. NO.	WAHER DIP TYPE
.XXX±0.10	.XXX°±0.5°	单位 Units	张名	mm	版本 REV.
		SCALE	比例	7	页次 SHEET
					1/1

乐清市宏一电子有限公司  
YueDing HongYi Electronics Co., Ltd

SPECIFICATIONS

- 1、 Current Rating: 3A AC, DC
- 2、 Voltage Rating: 250V AC, DC
- 3、 Temperature Range: -25°C~+85°C
- 4、 Contact Resistance: 20mΩ Max
- 5、 Insulation Resistance: 1000MΩ
- 6、 Withstanding Voltage: 1000V AC/minute
- 7、 Material: Wafer PA66, UL94V-0  
PIN Phosphor bronze Tin-plated

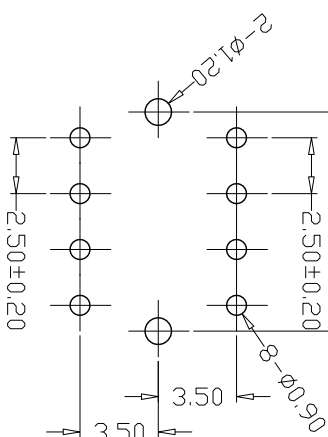
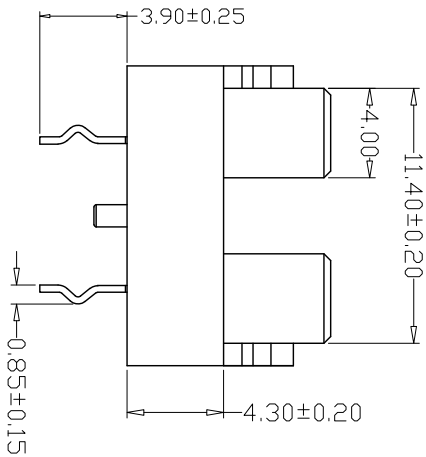
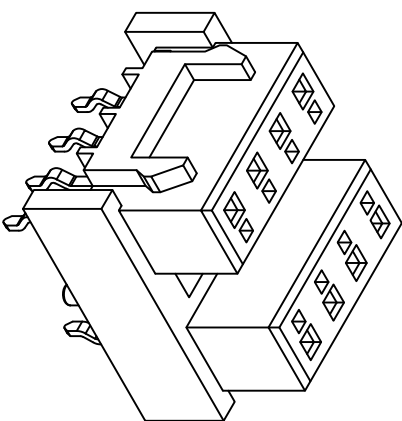
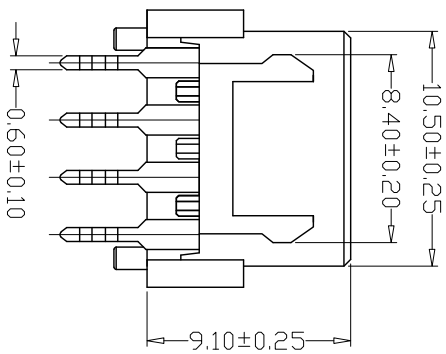
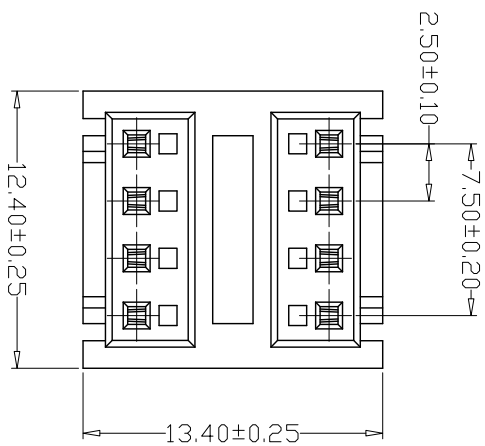

PCB LAYOUT

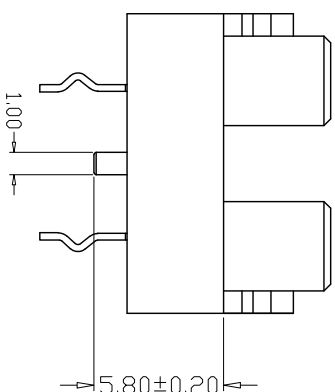

版本 REV.	日期 DATE	变更内容 DESCRIPTION	制图 DRAWN

GENERAL TOLERANCE		制图 Mapping		料号 PART NO.		版本 REV.	
X±0.25	X°±2°	张迎春 2022、09、15	张迎春	A25010-2*4P	A		
X±0.25	X°±1°	审核 Audit	钱岳生	XH板对板双排直针 WAHER DIP TYPE			
.XX±0.15	.XX°±0.5°	核准 Approved	张名	客户料号 CUST. NO.			
.XXX±0.10	.XXX°±0.5°	单位 Units	2022、09、16				
		mm	比例 SCALE				

乐清市宏一电子有限公司  
Yueqing HongYi Electronics Co., Ltd

版本 REV.	日期 DATE	ECN NO.	变更内容 DESCRIPTION	制图 DRAWN

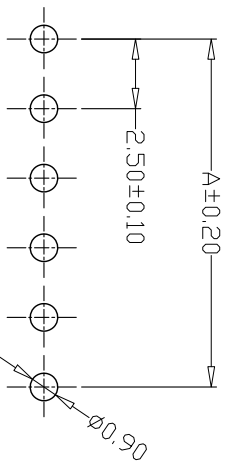
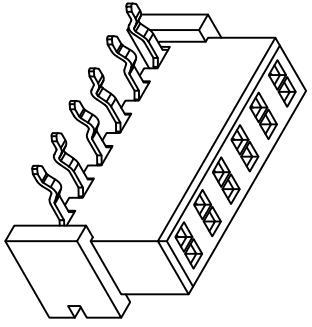

- SPECIFICATIONS**
- Current Rating: 3A AC, DC
  - Voltage Rating: 250V AC, DC
  - Temperature Range: -25°C~+85°C
  - Contact Resistance: 20mΩ Max
  - Insulation Resistance: 1000MΩ Min
  - Withstanding Voltage: 1000V AC/minute
  - Material: Wafer PA66, UL94V-0  
PIN Phosphor bronze Tin-plated

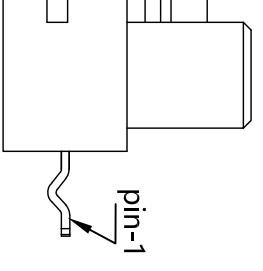
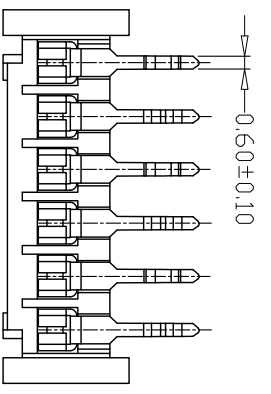
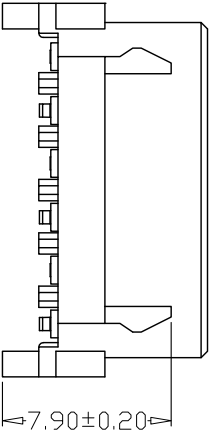
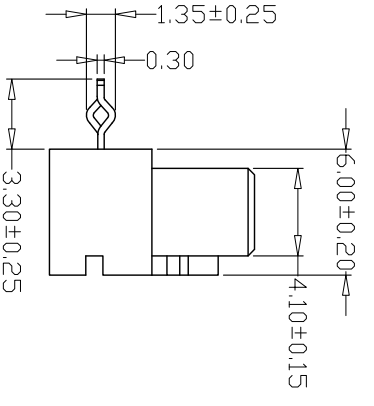
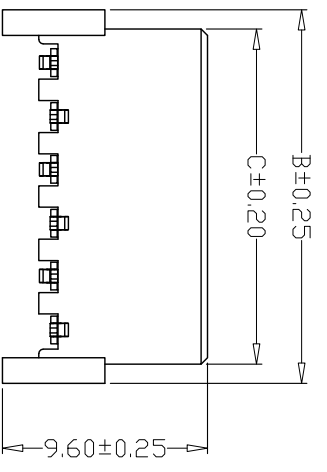
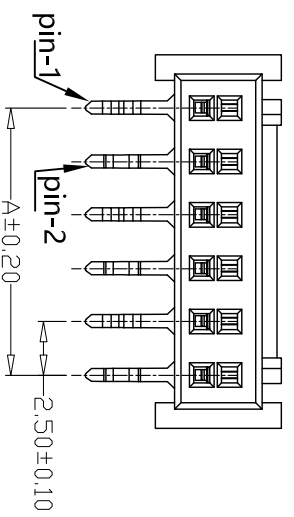

任何孔位第1针打孔方向

**PCB LAYOUT**

PIN	尺寸 (mm)		
	A	B	C
-02PW	2.50	7.50	5.70
-03PW	5.00	10.00	8.20
-04PW	7.50	12.50	10.70
-05PW	10.00	15.00	13.20
-06PW	12.50	17.50	15.70
-07PW	15.00	20.00	18.20
-08PW	17.50	22.50	20.70
-09PW	20.00	25.00	23.20
-10PW	22.50	27.50	25.70
-11PW	25.00	30.00	28.20
-12PW	27.50	32.50	30.70
-13PW	30.00	35.00	33.20
-14PW	32.50	37.50	35.70
-15PW	35.00	40.00	38.20

GENERAL TOLERANCE		制图 Mapping		料号 PART NO.	
X±0.25	X°±2°	张迎春	2022、09、15	A25010-nPW	版本 REV.
X±0.25	X°±1°	钱岳生	2022、09、15	XB板对板弯针	页次 SHEET
.XX±0.15	.XX°±0.5°	核准 Approved	张名	客户料号 CUST. NO.	1/1
.XXX±0.10	.XXX°±0.5°	单位 Units	张名 SCALE		
		mm	7		

乐清市宏一电子有限公司  
YueDing HongYi Electronics Co., Ltd